

Application-technical Conditions for the Transport, Building in and Maintenance of Products Manufactured by OROSházaGLAS Ltd.

Table of contents

	Side
1. COATED GLASSES	2
1.2. Pyrolytic coated glasses	2
1.3. Vacuum-magnetron coated glasses	3
1.4. Definition of the coated side	6
1.5. The risk of breakage caused by heat	6
1.6. Spontaneous breakage	7
2. ENAMELLED (SILK SCREEN PRINTED OR PAINTED) GLASSES	7
2.1. About enamelling in general	7
2.2. Enamel glazing (with silk screen printing or cylinder printing)	7
2.3. Parapet (painted on the whole surface) glasses	8
3. INSULATING GLASS STRUCTURES	8
3.1. Terminology	8
3.2. Dimensions, dimensional tolerances	8
3.3. Technical requirements	9
3.3.1. Spacer penetration	9
3.3.2. Requirements towards the primary (butyl) sealant	9
3.3.3. Requirements towards the secondary sealant	10
3.3.4. Appropriate layering of thermal insulation glass containing parapet painting	10
4. CONSTRUCTION GLASS STRUCTURES	10
4.1. Introduction	10
4.2. The production of construction glass structures, preparation of production	10
4.3. The building in of construction glass structures	11
5. GENERAL INSTRUCTIONS FOR EVERY GLASS TYPE MANUFACTURED BY OROSházaGLAS Ltd.	11
5.1. Quality control, allowed surface flaws in case of printed glasses	12
5.2. Quality control, allowed flaws	13
5.3. Physical phenomenon	14
5.3.1. Doppelscheiben effect	14
5.3.2. Interference	15
5.3.3. Anisotropy	15
5.3.4. Condensation on the outer (#1) or inner (#4) surface of the glass	16
5.4. Packaging	16
5.5. Transport, storage, installation	16
5.6. Cleaning, maintenance	18
5.7. Guarantee	19
5.8. Complaint management regulations	19

1. COATED GLASSES

1.1. Introduction

There are two main functions to be distinguished in case of coated glasses:

- a.) Sun protection – protection against sunbeam.
- b.) Heat protection – keeping heat-energy inside the building.

These two functions can appear separately – separately on each glass-layer – or combined – multifunctional – on the same glass. Considering the way of coating generally two coating types can be distinguished:

- a.) Pyrolytic (hot coated), or so called “hard coating”
- b.) Vacuum – magnetron, or so-called “soft coating”

Both processes make it possible to produce glasses with sun protective or heat protective function. With the vacuum – magnetron coating a wider range of colours are available in case of sun protection glasses, and better heat protection can be reached in case of heat protective glasses.

1.2. Pyrolytic flashed glasses

1.2.1. Sun protection glasses

By the production of float glass with online coating after the hot glass composition left the melting furnace, its surface gets a metal-oxide coating. The chemical composition of these oxides provides the high resistance ability and durability of the glass. The mostly applied chemical film-forming methods:

- a.) Spray coating: On the hot surface of the base glass the sprayed liquids evoke a pyrolytic reaction.
- b.) Vapour phase chemical coating: The vapour phase compounds evoke a chemical reaction on the hot surface of the base glass.

There are two widely-known coating types:

- a.) Slightly laurel like (bronzine) colour coating.
- b.) Bluish neutral (argent) colour coating.

These two coating types can be sprayed both on achromic and on its material coloured glasses.

These kinds of glasses are applied both monolithic and in insulating glass structures. In insulating glass structures the coating lays in position 1 or 2. More usual is the application in pos. 1 (see **figure 1**).

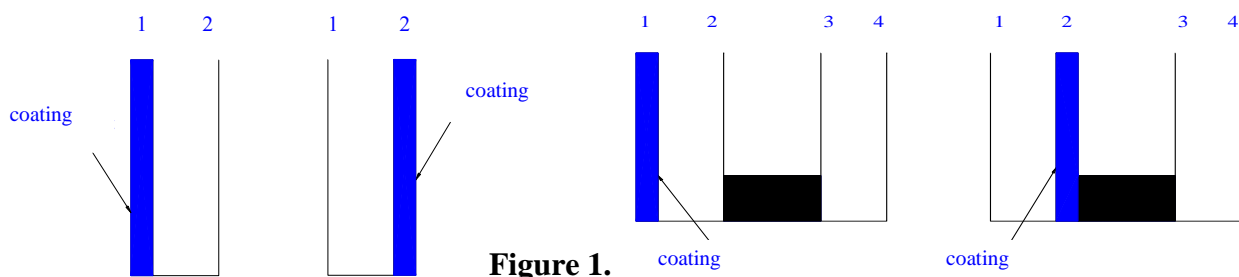

Figure 1.

These glasses can be at will machined, heat treated, laminated. The coating is hard, or rather layer stable, therefore its machining claims no special preparations, measures.

1.2.2. Heat reflecting or low-emissivity glasses

By the production of float glass with online coating after the hot glass composition left the melting furnace, its surface is sprayed with metal-oxide coating in μm thickness, on about $600\text{ }^{\circ}\text{C}$, which gets into fusion with the material of the glass. Then the glass is recooled together with the coating. The coating is almost clear, and one of its most important characteristic is that its irradiating ability is trifling; it means that it reradiates the warmth into the room, witch saves energy.

This coating type can be put both on achromic and on its material coloured float glasses, it is practically impossible to be removed mechanically (only the glass will be scratched).

These kinds of glasses are generally applied in insulating glass structures, where the coating lays in position 2 or 3. More usual is the application in pos. 3 (see **figure 2**).

The heat transmission coefficient:

In case of a 4 – 16 – 4 structures

$U_g = 1,9\text{ W/m}^2\text{K}$ filled with air

$U_g = 1,5 - 1,6\text{ W/m}^2\text{K}$ filled with argon

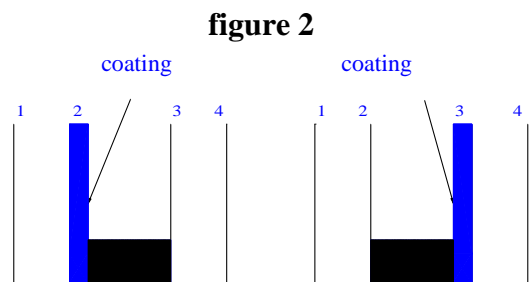

These glasses can be at will machined, heat treated, laminated. The coating is hard, or rather layer stable, therefore its machining claims no special preparations, measures.

1.3. Vacuum – magnetron coated glasses

1.3.1. Sun-protective glasses

By the production of float glass with offline coating the cool down, properly solidified, cut into basic dimension glass is taken to a so called coating line, where with the help of vacuum – magnetron technology a multilayer metal / metal-oxide coating system is applied on its surface. The coating – the ultra thin layers – does not burn into the material of the glass, but due to its mechanical adhesion – well adhering layers – it stays on the glass surface (see **figure 3**). The coating is easy to remove, for this reason it is essential to avoid the damages on the surface. The most frequently used physical film-forming method:

Cathode dispersion: In a vacuum chamber during electric gas discharge (due to an electric field argon gas is being ionized), the accelerated argon ions are bombarding a cathode electrode with high speed; witch makes the material spread, atomic dimension particles are dislodged, which are bombarded on the surface of the glass. The particles of metals and their alloys with or without adding supplementary reactive gases (O_2 , N_2) are sprayed (this makes it possible to make a metal, metal-oxide or metal-nitride coating on the surface of the base glass).

This coating type can be sprayed both on achromic and on its material coloured glasses.

The arrangement of the single coating layers – imitated on a general scheme:

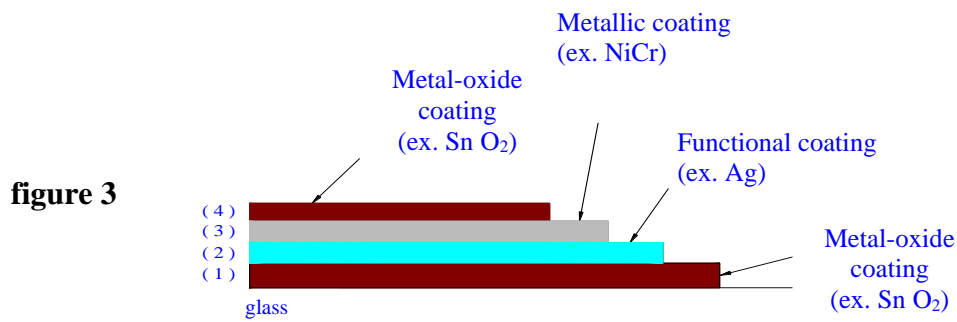

(1) Metal-oxide coating:

- protects the functional coating from the impacts might be caused by the glass
- diminishes reflexion (Lr)
- provides for the adequacy of the quality of the coating layer

(2) Functional coating (silver):

- gives a greater reflecting power against infrared (UV) radiation
- it is very soft and receptive against chemical impacts

(3) Metallic coating:

- it serves for the protection of the functional coating against chemical and physical impacts

(4) Metal-oxide coating:

- further improvement of protection
- through antireflection it provides for a greater level light transmission

If these glasses are used in insulating glass structures the coating lays in position 2. (See **figure 4**)

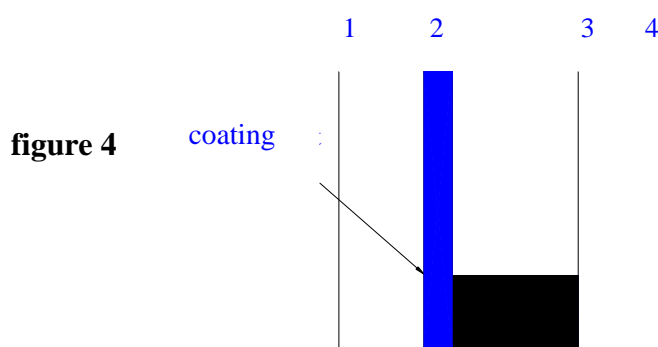

With respect to the machining and heat-treating abilities previous consultation with the producer is required.

Technologically: When assembling insulating glass, these glass types require no edge stripping.

1.3.2. Heat protective or so called low emissivity (LOW-E) glasses

By the production of float glass with offline coating the cool down, properly solidified, cut into basic dimension glass is taken to a so called coating line, where with the help of vacuum – magnetron technology a multilayer metal / metal-oxide coating system is applied on its surface. These coatings have the characteristics of good light transmission, homogeneity and colour neutrality. The coating is easy to remove, for this reason it is essential to avoid the damages on the surface.

Although the sunlight and sun heat can go through the window practically unhindered, the coating impedes in a great extend that heat leaves the room, so the energy of the sun can be used very effectively in the improvement of the heat balance of buildings. This phenomenon is due to a very effective, functional coating made of noble metal, which works as a light reflection medium in the infrared range.

These types of glasses are used in insulating glass structures, where the coating is in position 2 or 3 (the coated side must be towards the air gap between the two glass sheets). It is more usual to use it in pos. 3 (see **figure 5**).

figure 5

The heat transmission coefficient:

In case of a 4 – 16 – 4 structures

$U_g = 1,4 - 1,5 \text{ W/m}^2\text{K}$ filled with air

$U_g = 1,1 - 1,3 \text{ W/m}^2\text{K}$ filled with argon

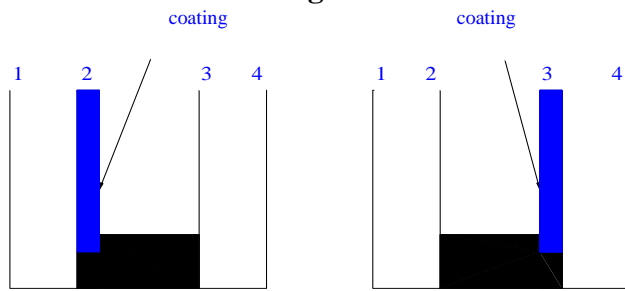

With respect to the machining and heat-treating abilities previous consultation with the producer is required.

Technologically: When assembling insulating glass, these glass types require edge stripping. Before washing, the coating must be grinded off through the boundary line (see **figure 6**).

figure 6

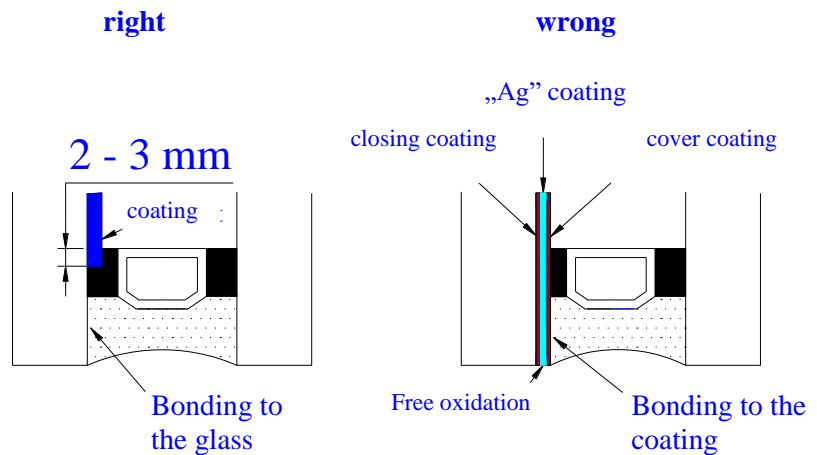

The coating is removed with abrasive disk. For this reason there are traces of the grinding throughout the edges. This cannot constitute the subject of any complaint. At heat treated glass panes, increased optical distortion may occur at a surface where Magnetron coating has been removed. As wide is the removal as greater the distortion might be. This optical phenomenon is due to the physical properties of the glass, therefore it can not be the subject of any complaint.

1.3.3. Multifunctional (sun and heat protection) glasses

The application of the coating is similar to the method described in the foregoing; it is easy to remove, so it requires increased care for the avoidance of surface damages and oxidation. These types of glasses are used in insulating glass structures, where the coating is in position 2 (see **figure 7**)

figure 7

The heat transmission coefficient:

In case of a 4 – 16 – 4 structures

$U_g = 1,5 - 1,8 \text{ W/m}^2\text{K}$ filled with air

$U_g = 1,2 - 1,4 \text{ W/m}^2\text{K}$ filled with argon

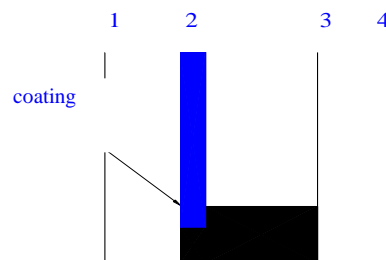

With respect to the machining and heat-treating abilities previous consultation with the producer is required.

Technologically: When assembling insulating glass, these glass types require edge stripping! The coating is removed with abrasive disk. For this reason there are traces of the grinding throughout the edges. This cannot constitute the subject of any complaint. At heat treated glass panes, increased optical distortion may occur at a

surface where Magnetron coating has been removed. As wide is the removal as greater the distortion might be. This optical phenomenon is due to the physical properties of the glass, therefore it can not be the subject of any complaint.

1.4. Definition of the coated side

It is essential to know, which side is coated. In case of metallic coating types due to the conductor layer it is easy to find out with the help of an ohm-meter, on which side the coating is (see **figure 8**). Universally the “traditional” way is very easy to apply (see **figure 9**).

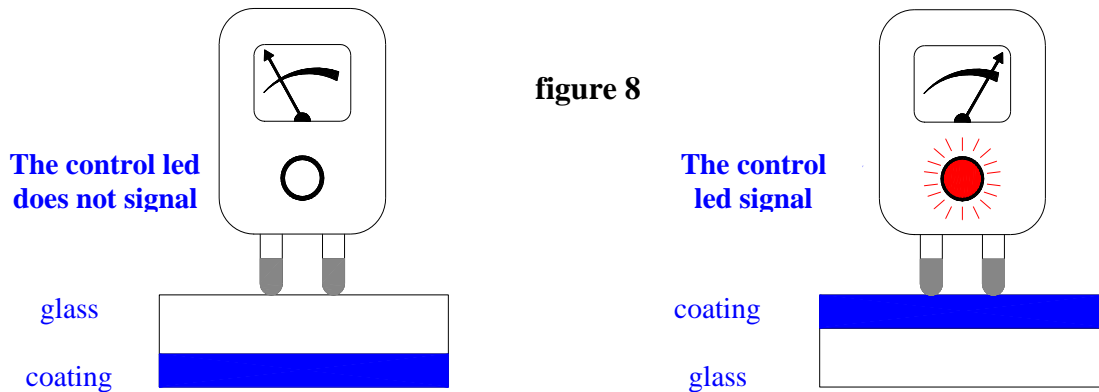
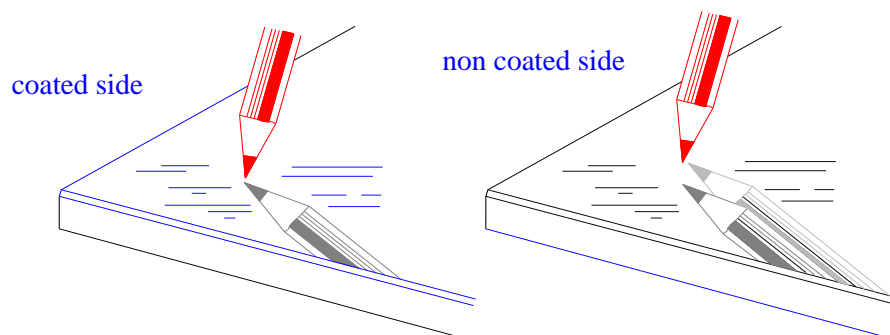

figure 8

figure 9



For insulating glasses the so called “flame test” can be applied. Keeping a lighter in front of the structure, 4 tongues of flame can be seen mirrored on the glass. 3 out of them have the same colour, while the 4th one is different. This different coloured flame shows, in which position the coating on the glass lays reckoned from the examined side.

1.5. The risk of breakage caused by heat

Heat breakage can be caused by several reasons. These factors are the following:

- The state of the glass edges (hack),
- Type and material of the sash (quick heat loss),
- Energy absorption of the glass (strong warming-up – EA > 60%),
- (Strong) shadow caused by building edges, trees, half-opened shutters, exposure of the building etc.

The bad heat conductivity and expansion attitude is rigid. The combination of all or several of these factors can cause mechanical tension within the sheet due to temperature differences. If this tension exceeds a critical value, it results on breakage. Wit heat treatment (heat strengthening) the possibility of heat breakage can be eliminated in most of the cases. It is recommended to make a heat analysis on the glazing project or have consultation with the producer.

1.6. Spontaneous breakage

By single-sheet safety (heat treated) glasses occasionally spontaneous breakage can occur, which can be tracked back to inclusions (e.g. nickel sulphide). In these cases the inclusions may get into the material during the float glass producing method. In case of a breakage the single-sheet safety glass will break into numerous cullets, which are either wedged into each other or fall out from the aperture as a breakage piece. The occurrence of such breakages is very rare after the building in, it is only probable in case of extreme wind load or temperature change.

On fields, where heat treated safety glazing is prescribed; OROSházaGLAS recommends and on demand performs heat soak tests on the glasses. When heated, the capacity of the nickel sulphite inclusions grows. After it occurred, tiny cracks enter into the compression layer of the single-sheet safety glass. This impulsive energy liberation leads to the spontaneous breakage. The heat soaking makes this heating and expansion process faster. If there are inclusions in the glass, these breakages will occur in all probability during the heat soak test and not after building in. In spite of that heat soaking cannot fully guarantee that the glass kept warm than built in will not spontaneously break. But the probability that nickel sulphite inclusions will cause breakage can be significantly decreased.

2. ENAMELLED (SILK SCREEN PRINTED OR PAINTED) GLASSES

2.1. About enamelling in general

Types of enamel glazing:	painting on the whole surface, raster or décor painting
- Painting on the whole surface:	Enamel surface without interrupt on the whole surface of the glass. Can be made with silk screen printing or cylinder printing.
- Raster painting:	Partial printing with a dot tending towards the inner side of the glass or with whole-raster. Can be made with silk screen printing.
- Décor painting:	Geometrical lines in an arrangement of choice, logos. Can be made with silk screen printing. Décor painting can be done by using multiple colours.
- Filament painting:	A special case of the décor painting, when filament is painted on the glass with the help of a special paint.

The painted glasses look optically better, if the painted layer is on position 2. Independently, in case of indoor application (e.g. doors) visibility from both sides is inevitable. In such a case it must be accepted that on the painted side cylinder tracks, round pin sized lacks of paint, grains and paint flow can be seen. This cannot constitute the subject of any complaint. When this is unacceptable we recommend the application of glasses laminated with coloured foil.

2.2. Enamel glazing (with silk screen printing or cylinder printing)

Under decorative silk screen printing we mean lines, dots etc. applied on the coating. The optical quality is excellent, the adhesion is not as good as on glasses with no coating, but it is suitable for the most application purposes and brings a sufficient result. It is possible to apply an enamel glazing brought up by silk screen or cylinder printing on the whole surface of the glass, when nothing is aimed to be cemented between the enamelled coating and another object. If there is yet something to be cemented, structural glazing or insulating material, it is recommended to make a compatibility test. Another option is the binding on the enamel-free edge of the glass (see **figure 10**)

figure 10

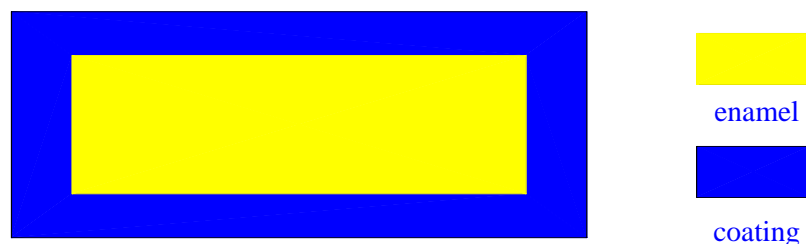

Enamelling can be used for lapping the assembly components near the edges. In case of structural glazing enamelling the edges provides protection against the UV radiation, which makes possible to use sealants e.g. thiokol. This can improve the U_g – values significantly (see **figure 11**).

figure 11

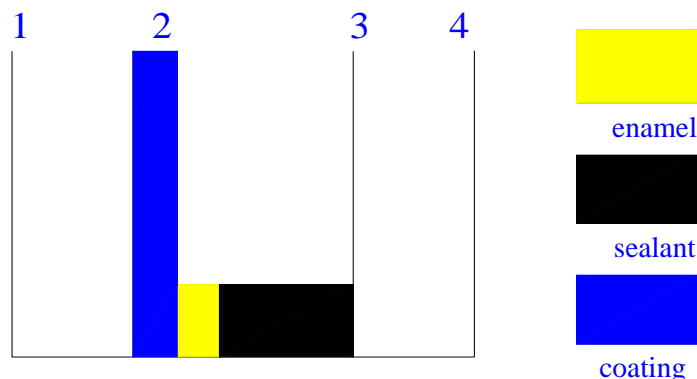

It can occur that the adhesion of the paints and the enamel-coatings to the coated side is weaker than the adhesion of the sealant contacting with the glass or the coated surface. Here it is also recommended to make a compatibility test between the sealant and the enamelling.

2.3. Parapet (painted on the whole surface) glasses

Sun protective glasses with pyrolytic coating can be painted on both sides. In case of the application of heat protective glasses with pyrolytic coating enamelling has no sense. In case of the application of vacuum – magnetron coating it is necessary to consult with the producer about the possibilities of heat treating and in harmony with this about the possibilities of colourability and enamelling.

In gleam the parapet glass does not show a fully-constantly coated surface, therefore its application in such building-in situation not recommended. If it is still applied, prior consultation with the producer is necessary.

3. INSULATING GLASS STRUCTURES

3.1. Terminology

Insulating glass: A structure consisting of at least two layers, separated by one or more spacers, closed down hermetically by the edges.

Spacer: That part of the structure of which main function is to secure the air gap, respectively the storage of the absorbent. It can be made of steel, aluminium and plastic.

Absorbent: A material decreasing the humidity in the inside of the insulating glass.

Primary sealant: Butyl running through the whole outline of the spacer.

Secondary sealant: Its purpose is the final sealing of the structure and fastening the components to each other.

Edge breadth: A stripe running around the glass structure bordered by the edge of the glass sheets and the inner edge of the spacer profile.

3.2. Dimensions, dimensional tolerances

Smallest producible size: 300 X 400mm

Biggest size: 2500 X 5000mm

Allowed plane dimensional divergences of the insulating structure:

- Up to 1 000mm $\pm 1\text{mm}$
- 1 000 – 2000mm $\pm 2\text{mm}$
- Above 2 000mm $\pm 3\text{mm}$

Structural thickness: nominal size $\pm 1\text{mm}$

Deviation from the right angle: according to EN 12150

Edge crookedness: the allowed edge crookedness can be 0,3 % of the examined side length.

3.3. Technical requirements

Spacer width: 5, 6, 7, 9, 10, 12, 14, 15, 16, 18, 20, 22, 24mm in case of polysulphide and silicone, but when applying a “U” gutter the smallest spacer recommended by OROSházaGLAS is 15mm.

In case of a sectional “U” gutter finish the “U” profiles get into one line, but a $\pm 1,5\text{mm}$ deviation compared to the hypothetical axis can occur; furthermore the “U” gutter can turn away from its own centre by max. $\pm 1,5\text{mm}$. Therefore in case of ordering sectional “U” gutter glass we recommend to use an “L” fastener instead of the standard e.g. SCHÜCO “T” fastener when building in.

3.3.1. Spacer penetration

- In case of poly-sulphite 15mm maximum
- In case of silicone sealing 16mm maximum
- In case a “U” gutter it is a question of a particular agreement, since the sealing depth depends on the size of the applied “U” gutter. Universally: height of the “U” gutter + 3mm silicone + height of the spacer = nominal size. Tolerance: 0, +3mm
- Within the above given values the position of the spacer cannot constitute the basis of quality complaints.

3.3.2. Requirements towards the primary (butyl) sealant

The butyl must be continuous all around the outline of the spacer, no tear is allowed. Issued from the technology during the production of insulating glass the even spread of the butyl is unaccomplishable, so in the inner edge of the spacer it can reach over with 2mm. Since the butyl coverage of the whole surface of the spacer is not applicable, the surface of the spacer will not form a homogenous unit. To avoid this it is recommended to use anodized (eloxed) spacers in case of structural sealing.

Deviance in the two neighbouring edges of the insulating glass (see **figure 12: X**) at right angles to the plane of the sheet

- Up to 2000mm: max. 2mm
- Above 2000mm: max 4mm

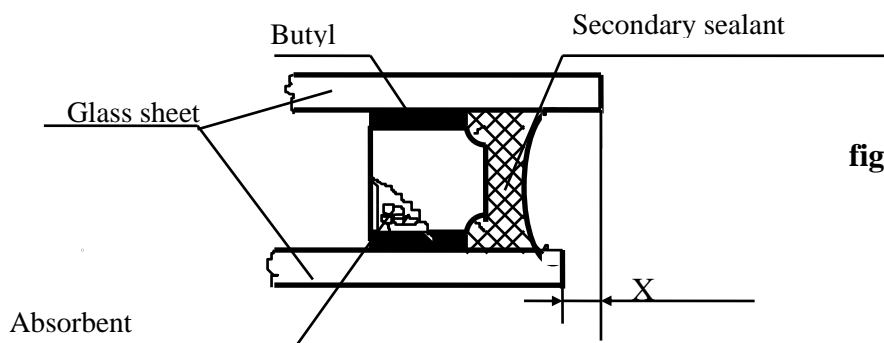

figure 12

3.3.3. Requirements towards the secondary sealant

The sealant must be continuous, visible holes, pores, gaps are not allowed, lack of material are not permitted. An exception is those, put down in point 3.3.2. The sealant has to be homogenous all around the outline, marmorisation is not permitted. Bonding inequality due to new start, if airtight sealing is not influenced, is not objectionable. On the edge of the glass the sealant can reach over with max. 2mm.

The hardness of the sealant has to be checked in accordance with the prescription of the producer of the material.

3.3.4. Appropriate layering of thermal insulation glass containing parapet painting in case of one air gap

when using **low-e glass**:

- position 2 painted
- 3-position low-e coating

in the case of **multifunctional glass**:

- position 2 multifunction coating
- position 4 painted

In additional we recommend that the width of the **air gap** delimited by painted glass should **not exceed 12mm**.

On the whole surface dot raster - shielded - glass is not treated as a parapet. In this type a different order can be applied.

In the case of two air-gap glass, the coating and painting position must be determined following the above logic.

4. CONSTRUCTION GLASS STRUCTURES

4.1. Introduction

The construction glass structures (face glass-walls and glass roofs) represent an outstanding value, but as a result of their nature, their production and assembly claim increased technological discipline. These can become a safe structure only if handled with peculiar precaution, prepared and built together properly and complied with the instructions. In order to secure the guaranteed high quality there must be a close cooperation between the designer, the contractor for the metal structure, the supplier of the raw material and appliances and the producer and installer of the structural glass components.

4.2. The production of construction glass structures, preparation of production

4.2.1. The construction glass structure components for different systems are produced by OROSházaGLAS under the quality supervision of the silicone producer. For every single project a questionnaire called “Structural Glazing Project” must be filled out. Before the start of production the detailed finishing plans and the questionnaire must be checked against each other, the production of the glass components can only be started if the building structural environment is approved as well as the applied glass type by the silicone producer.

4.2.2. In case the glass components are fixed on a kind of frame with structural silicone, a prescribed sample from the silicone receiving profile (from every surface-treated serial of the given order) has to be given to the silicone supplier for a lab test for choosing the primary material and for checking the surface bond. The whole lab test might take 7 weeks (this must be taken into consideration when scheduling the completion), of which results are documented towards OROSházaGLAS by the silicone producer.

4.2.3. The glass type to be applied must be previously reconciled with the representative of OROSházaGLAS. The approval of OROSházaGLAS and the producer of the silicone cannot serve as a basis of taking responsibility from general safety, indoor heat and conditioning technical, lighting technical, ergonomic etc. point of view. This is only for checking structural compatibility.

4.2.4. Because of the danger of transport, process handling and heat breakage the outer flat glass sheets must be hardened or heat-strengthened.

4.2.5. The production of components for glazing purposes – harmonized with the general European norms – can be only started after the approval of the silicone producer.

4.2.6. The adhesive agents – sealants (butyl, silicone, bedding tape) used for the production and applied next to each other have a black or gray character, but differences in the shading among them can be discovered. Their application is separated in time; therefore, the inhomogeneity of the edge stripe cannot serve as basis for objection. The spreading of the butyl on the ALU spacer is not even, so in some cases at the junction of the butyl and silicone the spacer becomes visible. If it is disturbing from aesthetical point of view, we recommend the application of anodized (eloxed) spacers or a dark paint for masking the sealant on the surface of the outer glass.

4.3. The building in of construction glass structures

- In case of applying one-component structural silicone the glasses can be delivered only 14 days after the sealing of the edges. The producer cannot deliver it earlier.

- In case of applying two-component structural silicone the glasses can be delivered after 24 hours the earliest.

4.3.1. The glass can be built in 14 days after working in, in case of one-component structural silicone and 7 days in case of two-component structural silicone. An earlier expose to weather conditions endangers the final hardening phase of the adhesive agent.

4.3.2. The fix (grooved, mechanical fixable) glass components must be placed and fixed according to the scheduled detail drawing and assembly instructions.

4.3.3. The parapet and moving (bond to a metal frame with structural adhesive bonding) glasses are delivered together with the frames; their building in must be according to the scheduled detail drawing and assembly instructions. For lack of an individual agreement, the production of the frames and their delivery to Orosháza is the task and cost of the customer.

4.3.4. Making a structural adhesive bonding on the place of the building in (apart from exceptional, controlled cases) is prohibited.

4.3.5. The structural bonding of the fix, parapet and moving glass components must be insulated against precipitation effects in spite of the fact that according to the qualifications the bonding must be waterproof. The gap between the two glass components or the glass component and the joining metal structure must be waterproof sealed with weatherproof silicone joint sealant. The pointing silicone, after its application to the cleaned surfaces, must be pulled down (so that it is pushed into the gaps) with a glazing knife. The pointing silicone to be applied must be checked for compatibility in the lab of the secondary sealant producer. In case of open joint structures the free flow-off of precipitation must be secured. It is a basic principle that the glass cannot stand in liquid.

5. GENERAL INSTRUCTIONS FOR EVERY GLASS TYPE MANUFACTURED BY OROSházaGLAS

Inspection method

When inspecting the light reflection the controlling person looks at the outer side of the glazing. Light transmission is examined from the inside to the outside. For the characterization of the flaws he must stand at least 1m from the coated glass (see figure 13). The inspection must be carried out under evenly overcast sky in daylight, without direct sunlight.

figure 13



5.1. Quality control, allowed surface flaws in case of printed glasses

The breadth of the edge lapped with coverage can be ignored for an extent, where it does not influence the function of the glass sheet. Checking takes place in light corresponding to daylight, in front of a dark background, in 1 meter of examination distance, about 30 seconds long.

5.1.1. Colour effect and transmission

Colour effect is valued on the basis of either a reference sample signed by both parties.

If the glass required for the glazing of the whole object is not ordered at once, due to the multiple production batches (glass, paint) unhomogeneity in colour can occur. In this very case the responsibility is the customer's.

5.1.2. Allowed measures of failures

5.1.2.1 General requirements

- a.) Paint traces of 0,5 – 1,0mm in a minimum distance of 200mm on the non-enamelled part are allowed.
- b.) Printing flaws which cannot be seen by examining them with putting the hand beneath is allowed.
- c.) The enamel-free or non-enamelled glass edge is maximum 3mm from the edge of the grinding or the bores are allowed.

5.1.2.2. Painting on the whole surface

The building-in of these (parapet) glasses in gleam is not recommended. Only the lack of paint to be seen in dark background will be accepted as complaint.

Other glasses as well as continuous and running-out dot-raster glasses:

Faulty area $\leq 0,5 \text{ mm}^2$	- not estimable
$0,5 \text{ mm}^2 < \text{Faulty area} \leq 1,0 \text{ mm}^2$	- max. 6 dots or line-shaped flaw in a distance of 50mm from the other one is allowed on a surface of 1m^2
$1,0 \text{ mm}^2 < \text{Faulty area}$	- max. 4 dots or line-shaped flaw in a distance of 50mm from the other one is allowed

5.1.2.3. Raster painting

- a.) Connected dots between the first half-dot line and the first full-dot line are not a faulty.
- b.) The not fully printed dots only count as full-dots if they are visible in more than 50 percent in intensity as well as in shape.

c.) Missing dots:

- Ø 0, 5mm - not estimable, inevitable owing to producibility
- Ø 0, 6 – 1mm - on a 50mm part 5 dots can be missing connected or scattered
- Ø 1 – 1,5mm - on a 50mm part 4 separate dots can be missing
- Ø 1,5 – 2mm - max. 1 flow on a 50mm part

5.1.2.4. Décor painting

A paint lack of 5%, which does not disturb the character of the design, is allowed.

5.1.3. Repairs

The repairing of the enamelling is allowed, if the diameter of the flaw is not bigger than 3mm or after building in the flaw cannot be seen any more, respectively the paint enamel coating continues to meet requirements.

5.2. Quality control, allowed flaws

For control purposes the surface of the glass sheets has to be divided into 3 zones (see **figure 14**)

- Zone 1: main range of vision
- Zone 2: subsidiary range of vision
- Zone 3: the edge of the glass sheet (if no other agreement, 18mm)

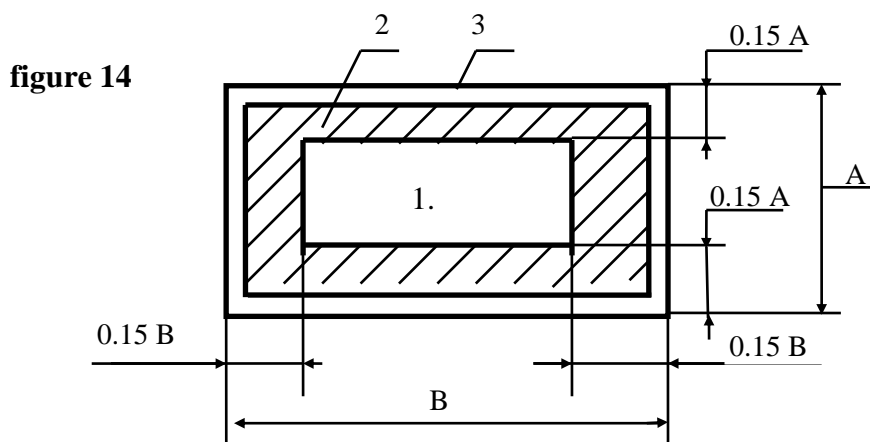

The examination has to be carried out in a way which is similar to seeing through the glass in the diffuse light of the sky without direct sunlight.

The eyes of the controller have to be in the same level as the centre of the sheet and he has to see through the glass from a distance of about 1m, at right angles to the sheet, about 5 seconds long.

The sheet can be judged as good if on the examined surface there are no flaws or they are not disturbing.

Type	Zone 1	Zone 2	Zone 3
Rough scratch	not allowed	not allowed	Every flaw is
Fine, with finger- nail perceptible	under 1m ² : 2pcs; above 1m ² : 2pcs/m ² with a min. 400mm	under 1m ² : 2pcs; above 1m ² : 2pcs/m ² with a min. 400mm	allowed, if the function of the

scratch	distance between them. Length of scratch: max. 20mm.	distance between them. Length of scratch: max. 40mm.	glass is not influenced.
Single hair scratch	under 1m ² : 2pcs; above 1m ² : 2pcs/m ² with a min. 400mm distance between them Length of scratch: max. 40mm.	under 1m ² : 2pcs; above 1m ² : 2pcs/m ² with a min. 400mm distance between them Length of scratch: max. 80mm.	
Bubble, stone or dot-like flaw	Size of flaw: ≤ Ø 2,0mm under 1m ² : 1pc above 1m ² : 1 pc/m ² with a min. 400mm distance between them.	Size of flaw: ≤ Ø 3 mm, under 1m ² : 2pcs; above 1m ² : 2pcs/m ² with a min. 400mm distance between them.	

5.2.1. Homogeneity flaws

These flaws are only acceptable, if the differences within a sheet or between the neighbouring sheets are not declared as disturbing by impartial, objective viewer.

5.2.2. Colour, reflection, light transmission

A minor change in colour, reflection and light transmission in front of a bright background, from a distance of more than 3m is acceptable.

Note (1): Coated glasses have a typical colour. This colour can have different kinds of recognisability when seeing through or at. The fluctuation of the colour depth is due to the iron-oxide content of the glass, the coating procedure, the type of coating, the thickness of the glass and the structure of the sheet and is inevitable.

Note (2): In case of glasses with sun-protective coating, especially by single-sheet insulating glasses, the optical distortion of the reflected object might be more striking. The tolerances allowed in connection with the deviances from the even are to be found in the relevant norms.

5.3. Physical phenomenon

These phenomena are independent from the base glass and the processor, so they cannot constitute the basis of any objection in case of insulating glasses.

5.3.1. Doppelscheibeneffekt (double sheet effect)

Due to the hermetically sealed air gap and the solid bonding throughout the edges acts like a membrane. As a result of air pressure and temperature a volume change takes place. The glass sheets will crook or bulge, which can be perceived as the distortion of the mirror image. Its extent depends on the size of the sheet and the breadth of the air-gap.

This phenomenon is physically imp edible, so it cannot constitute the basis of quality complaints. See **figure 15**.

figure 15

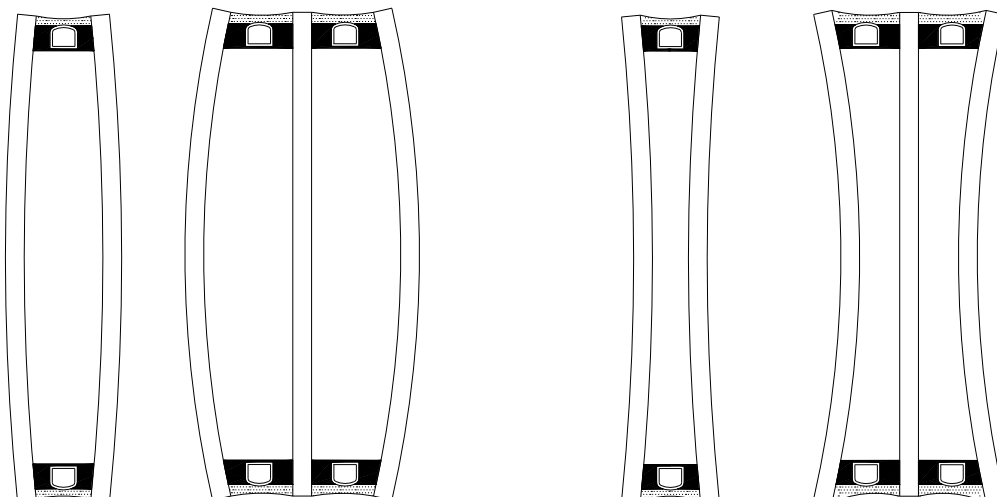

Barrelling caused by the **heating-up** of the air layer within the insulating glass structure

Barrelling caused by the **cooling-down** of the air layer within the insulating glass structure

5.3.2. Interference

In an optimal case the float glass is a plane parallel. Applying it in insulating glass structures, in several cases it might show a characteristic optical effect. This phenomenon shows up in a spot-like, striped or ring shaped (Newton ring) way, and if pushed, it changes its position. Interference is unambiguously a physical determined refraction, which is only visible if more float glass sheets are put behind each other. Its degree strongly depends on the local lighting conditions and the angle of descent. It is only visible through the existence of more factors and only when looking from a certain angle. So the interference is a physical phenomenon, which is the optical effect of the excellent float glass quality. See **figure 16**.

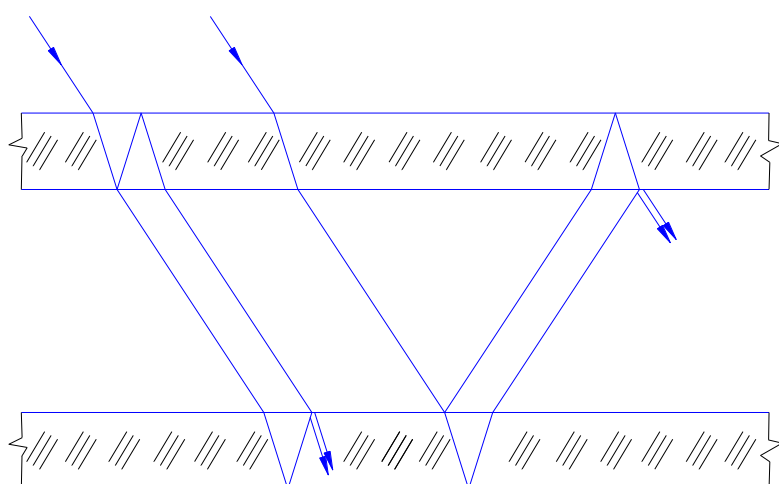

figure 16

5.3.3. Anisotropy

During the heat treating process the glass goes through special thermal process, this makes it “hardened”. This production process creates tension zones within the glass, which cause double refraction in polarized light. Under certain lighting conditions these polarization fields might become visible in spot-like shape. This is the

characteristic feature of the hardened glass; it is physically determined and cannot constitute the basis of quality complaints.

5.3.4. Condensation on the outer (#1) or inner (#4) surface of the glass

The temperature of the air, where the relative humidity is 100%, is called condensation point. With no change in the degree of humidity the decrease of the air temperature will cause the appearance of condensating water. Condensation point temperatures can appear in the following places:

a.) in the air gap of the glass structure

In case of a new insulating glass structure the condensation point temperature in the air gap must be $< -60^{\circ}\text{C}$, which guarantees the long lifespan of the structure.

b.) on the plane of the insulating glazing inside the building

Condensation may happen under the following circumstances:

1.) the warm air suddenly cools down on the colder, inner glass plane

2.) in case of relatively cold, high humidity air the blushing is caused by the condensation at the cold glass plane.

The degree of condensation disposition can significantly decreased by applying glass structures with better “Ug value”, and by ensuring proper ventilation of the room.

c.) on the plane of the insulating glazing outside the building

In case of coated heat-protective glasses, under certain circumstances condensation may happen – e.g. early in the morning, due to the higher humidity of the ambient air, – which is, through the higher thermal barrier, caused by the stronger cooling of the glass. However, the condensation water may be quickly dried up by the first rays of sunlight.

5.4. Packaging

The wrapping must protect the glass from every kind of damage (scratch, chip off, breakage etc.). Glasses can only be wrapped if carried to their extremes.

The wrapping, according to the agreement with the customer, can happen in cases, compartments, metal containers or on a stand. Between the glass sheets, in order to prevent them from damages, paper, corrugated paper, sticking sheet, pulverized soapstone, cork etc. must be used. The gap between the glass and the compartment must be filled up with a proper stuffing material, like Nikecell, wood wool etc.

On one means of wrapping only same sized or nearly the same size glasses can be wrapped, unless otherwise ordered by the customer. But in this case OROSházaGLAS will not take responsibility for damages caused during the transport.

5.5. Transport, storage, installation

For the transport of wrapped glass every kind of public conveyance can be used. During the transport the wrapped units must be placed in a way that the glass is in lengthways facing the engine. Against slipping and displacement, fixing to the platform of the vehicle, against sideways swinging and tumbling over, fixing to each other and to the side of the vehicle must be applied.

On an open means of transport the cargo must be covered with watertight canvas, which must be fixed to protect against rain. Humid wrapped units, resp. glasses must be wrapped and dried out.

The adverse conditions which might harm the non-coated glasses can also harm the coated glasses. Glasses must be stored in a place where they are protected against bad weather conditions. The storage of any kind of glass under the clear sky is to be avoided. Coated glass can be moved and handled with the usual means. In order to prevent the glasses from scratches the contact with hard materials (glass shatters, glass edges, metallic parts, sand-corn etc.) must be avoided. There always must be a divider material between the glass sheets, resp. the sheets must be divided with cardboard paper stripes or cork-like materials. The direct contact of two glass sheets must be avoided. If possible, do not write or stick anything on the coated side!

During the unloading, craning of the glass racks the glass sheets must be kept safe from bumping against the crane rope and hook, which may cause in the breakage of the glass sheets or the chipping of the edges/corners.

Craning and lifting in may only performed in calm weather with the help of a leading rope in order to avoid the bumping of the glasses against other objects and their damages caused by this.

Chipped, damaged or roughly scratched glasses mustn't be installed.

The glass racks kept on the spot (which are lifted with stretch foil wrapping in order to avoid contamination and scratches) must be fully unloaded and the sheets must be built in. In case it is not possible, the sheets left on the racks must be re-wrapped with stretch foil, so that they are kept from contamination and scratches. If only 1-2 sheets remain on the racks, it is practical to put extra weights on them, so that a blast of wind cannot push them over.

After the unloading of every single glass sheet the support bars must be leant back against the glass sheets left on the racks, so that a blast of wind cannot push the sheets off of the racks. This is particularly important at the end of the working time. The sheets leant against the wall are extremely dangerous, this is not permitted.

The glass sheets must be kept stood on their edges in every case, they **MUST NOT** be stored laid on their flat surface.

The cases should be kept side by side should not be put atop of one another.

The glasses stored on the spot must be protected from the sun (for example with a light colour canvas) in order to avoid heat breakage. This might cause extremely big damages, every glass sheet on the racks might get damaged, so an extra care must be taken.

When placing the racks stored on the floor the static characteristics of the reinforced concrete must be taken into consideration, so that the floor is not damaged under the weight of the racks.

During the installation of the glass sheets care must be taken that they lay up straight along the edges. If the glass sheet does not rest stably owing to the unevenness of the laying profile, it cannot be installed. In this case the profile or the factor causing the instability must be diminished, because the uneven bearing may cause glass breakage.

During the installation of the glass sheets care must be taken that the possibility of tightening does not occur, so if the aperture determined by the profile frame is too tight, the glass sheet cannot be installed, because the movement of the building (meteorological burden, temperature change, dilatation movement) may cause the breakage of the glass.

Similarly care must be taken with glasses mounted into too wide apertures. A laying up of the glass smaller than the leaning up according to the plan is not acceptable, because it can fall of due to the movement of the building, which might cause an accident.

During the installation of the glass sheets stepping on them is prohibited. In case it was specially asked for in the RFQ and we handed over our static certificates, only one person is allowed to stand on the sheet at a time, because we calculate with 1KN concentrated weight. Standing on the glass sheet of more than one fitter is perilous. When walking on the glass surface the fitter must step on the spots close to the profiles, the middle of the sheet must be walked round in order to avert accidents.

When putting on the pressing laths care must be taken that the screws are not driven too tightly, because it might cause glass breakage.

After the placement of the glass the surface must be protected in order to avoid the scratching of the sheets or the glass breakage caused by falling objects.

The person performing the installation must not wear hard sole or steel toe shoes, which might damage or brake the glass. It also must be avoided to wear shoes with reticular sole, where pebbles can stick, which might cause in scratches or breakage. If a damage is discovered on a sheet already built in (scratch, crack, shell, chipping), it must be replaced immediately.

The closing of the edges by the insulating glasses might be performed with poly-sulphite or silicone. The poly-sulphite is not UV proof, so the glasses sealed with it can only be built in into pressing profile structures. In case of structural placing the sheet gets spoilt and fogged, so under no circumstance can be deviated from the pressing profile fastening.

During the installation care must be taken that the glass is built in according to the layer order, so it cannot be put in inversely, which involves optical deviation and might cause breakage.

If the edge of the glass sheet contacts with chemical agents (silicone, paint etc.) in however way, a compatibility test must be performed.

5.6. Cleaning, maintenance

- The cleaning of the glass wall is only permitted on the surface of the glass, with a cleaning detergent, which is chemically PH-neutral (not aggressive) and free from abrasives. When cleaning, the possible restrictions of basic glass producer about the handling of the outer surface must be taken into consideration. It can be cleaned with every usual glass cleaning machine which is suitable for the cleaning of float or insulated glass structures made of coated glass.

- The normal construction insulating roof glass (hardened in the outside, laminated with a foil of at least 0,76mm in the inside) cannot be bored, grinded, cut or further processed. It cannot be stepped on even for cleaning purposes. It can only be stepped on if a weight dividing construction (plank, grid) is applied. The weight dividing construction must be fixed firmly and it cannot harm the glass. Furthermore, the person performing the cleaning must have a mountaineer exam. It means that all work safety instructions for performing work in height must be kept. For example, the person must possess a safety band fastened firmly to the construction. During the cleaning it is forbidden to stay under the roof. OROSházaGLAS takes no responsibility for glass breakage caused by cleaning or indirect consequences issued from it.

- During the cleaning of the glass sheets it is not allowed to step on them. In case it was specially asked for in the RFQ and we handed over our static certificates, only one person is allowed to stand on the sheet at a time, because we had calculated with 1KN concentrated weight. Standing on the glass sheet of more than one fitter is perilous. When walking on the glass surface the fitter must step on the spots close to the profiles, the middle of the sheet must be walked round in order to avert accidents.

- The person performing the cleaning must not wear hard sole or steel toe shoes, which might damage or brake the glass. It also must be avoided to wear shoes with reticular sole, where pebbles can stick, which might cause in scratches or breakage.

- During the cleaning no corrosive agents can be used. Commercially available glass cleaning agents must be used.

- When the work on the glass skin is performed using the alpine technique, care must be taken that the karabiners and other steel parts do not bump into the glass. It is important that the glass edge never and under no circumstances does not work as a rope lead, which means a concentrated and dynamic burden to the glass sheet. This might lead to glass breakage.

- It is expedient for the operator to let the glass structure inspected and cleaned periodically.

- The structural glass wall must be re-examined by an expert at least once a year or extra after a greater storm (e.g. wind storm). In case the inspection reveals damages in the sealing or the bonding, in order to secure proper examination and repairing the specialists of OROSházaGLAS must be informed.

5.7. Guarantee

The keeping of the “Application-technical Conditions” and the “General Terms and Conditions” is prerequisite of all complaints towards OROSházaGLAS.

OROSházaGLAS gives a 5 years guarantee for its products.

OROSházaGLAS gives a 10 years guarantee for the structural silicone bonding on the fix, parapet and moving constructions.

5.8. Complaint management regulations

- The goods should be considered accepted is the customer does not make a complaint in a reasonable time (8 calendar days). Later the supplier will not accept complaint.
- If there is no other accepted written quality agreement every product is made according to the supplier’s standard practice. The commercial standards, the accepted practice and tolerance refers to dimensions, thickness, weight, linearity, composition, technical and optical nature, evenness, surface, quality, tolerance deviation together with differences caused by different testing methods.
- Only written complaints are accepted and the examination procedure is according to the followings:
- The breakage during transportation should be indicated immediately in writing.
 - o The report has to be signed by the driver. One copy of the report should be attached to the complaint. The customer must sustain the breakage by photos. The damage and that the glass is still on the vehicle of transport must be visible on the photo. Otherwise that the damage occurred during the unloading can not be impeached. For this OROSházaGLAS Ltd does not take the responsibility.
- After making the complaint the glass should be handled as the good glass is handled (storing, packing, transporting). If there are other damages can be found on the sent back glass than the mentioned ones the OROSházaGLAS will have no chance to make corrections. Accordingly these products will not be credited.
- Glasses are subject to complaint are put into production like a new order. It follows from this that it is invoiced again.
- When the complaint is examined and accepted it is credited.
- The supplier will not accept complaint if the application conditions of the glasses do not fulfill the standards and don’t fulfill the required application-technical conditions mentioned in this document.
- We do not accept complaint for further-processed or built in glasses.
- In case of accepted complaint our obligation is only the free replacement of the glass no additional expenses will be paid.
- In case of disallowed complaints the costs of examination is charged to the customer.